

# RoHS - Solder Profile for SMT Components

Osram OS  
Pb-free Reflow  
Soldering  
Profile

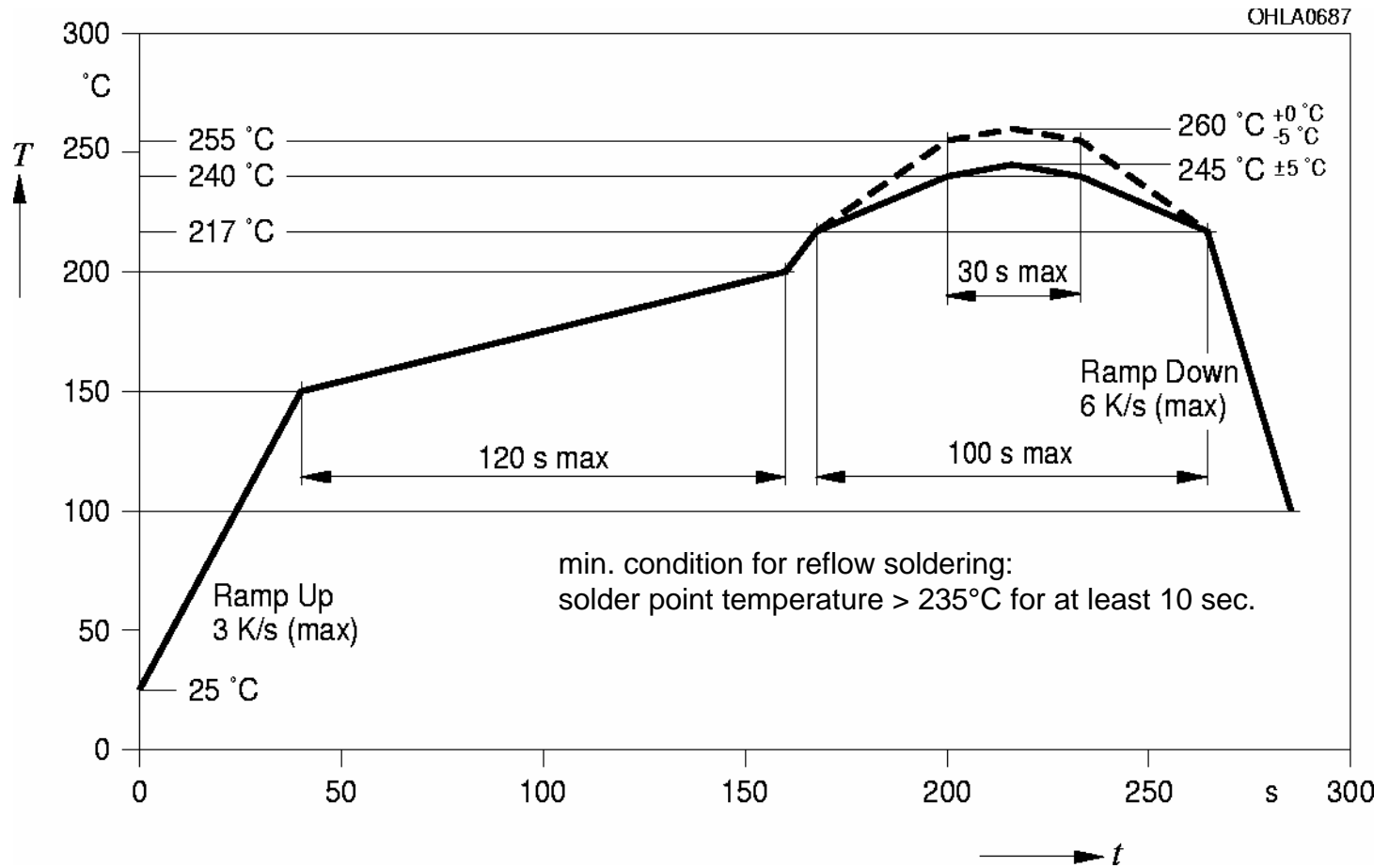

Acc. J-STD-020B

# RoHS - Solder Profile for SMT Components

## Temperature measurement for adjusting the reflow profile:

- Measurement at the solder joint, not at the top of the package.
- Peak temperature of 260°C at the solder joint is equivalent to 263 - 265°C at the top of the package.

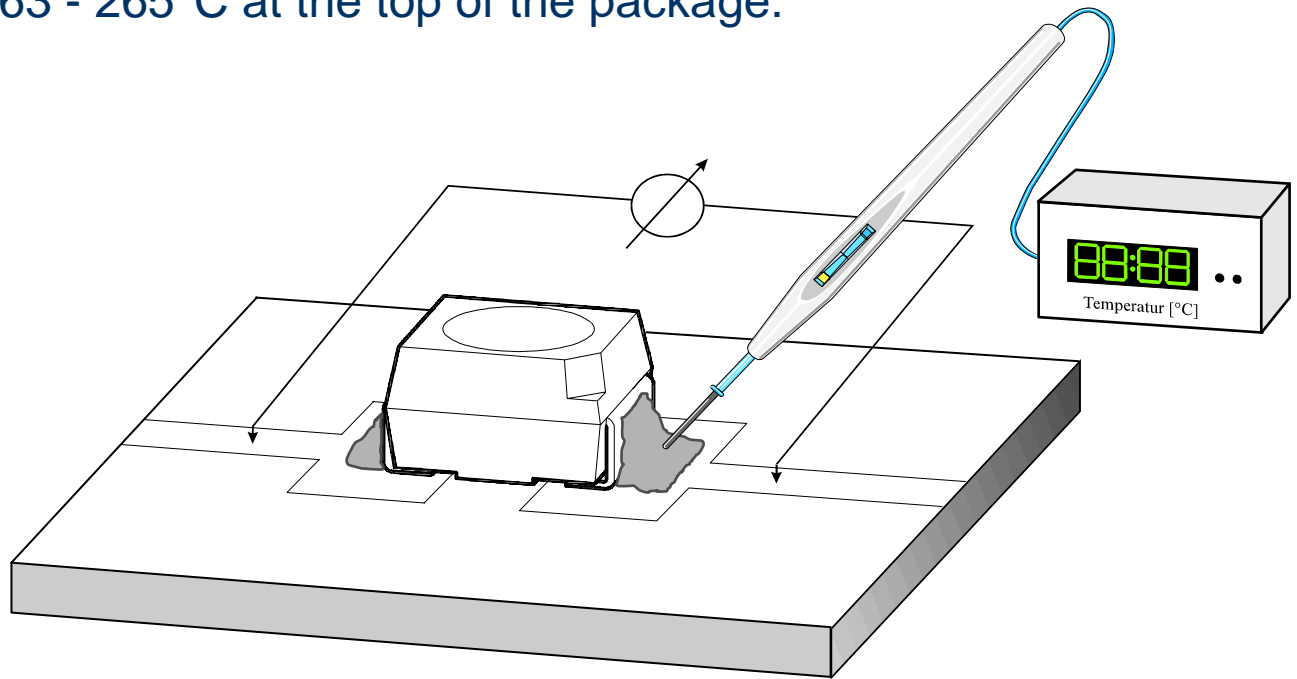

# RoHS - Solder Profile for Radial Components

Osram OS  
Pb-free Wave  
Soldering  
Profile

